

# LED Rainbow RGB LED Controller

## RGB Three-Channel LED Effects Controller

The **LED Rainbow** is an extremely simple and effective design – originally engineered to control RGB LED displays and arrays and has been adapted to multiple uses through its versatile setup. Three outputs are provided, with each capable of driving loads of LEDs, LED arrays, lamps or other devices. Attractive effects are achieved by running customized code on the built-in processor.

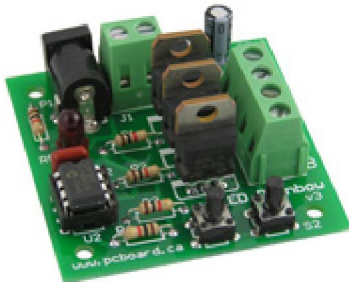

The unique design allows for the selection of various lighting effects and dimming sequences by selecting a routine from the onboard pushbutton. The processor will run pulse width modulation (PWM) to vary the intensity of three outputs (either single LEDs or LED arrays).

We continue to provide additional code and routines, and encourage you to visit our support web site at <http://www.pcboard.ca> to view the different coding sequences we provide at no extra charge. All are downloadable for free and can be programmed into your own PIC processor (providing you have a PIC programmer). Additional detailed support including coding information is also on

our support web site to assist you in creating your own effects.

The **LED Rainbow** is now in its third release. The latest design incorporates a power indicator LED at **D2**, professional grade rising clamp terminal blocks at the secondary power input and also on the outputs which simplifies connections to the board making wiring and experimentation easy.

The **LED Rainbow** is available fully assembled, as a kit of components you can build, or just the bare board allowing you to supply your own components. Average assembly of the kit in less than 30 minutes is possible. The board is a high quality, double-sided design, complete with solder masks on both sides, plated holes along with a high-contrast silk-screen labeling component positions measuring only 2" x 2" (51mm x 51mm).

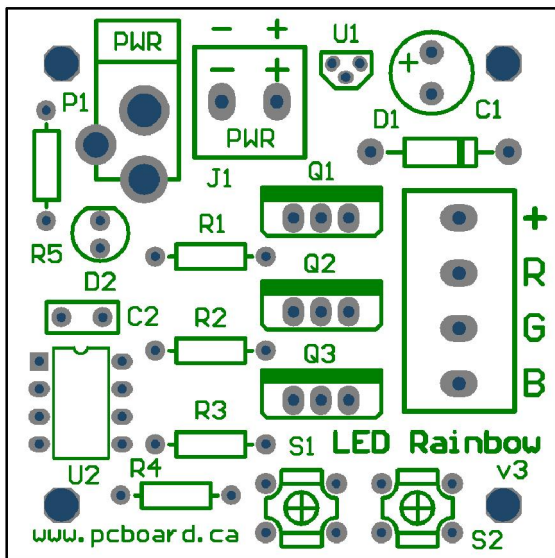

### Component List

- Resistor 1/4 watt, 5% Carbon Film:**  
 [ ] (5) 1K  $\Omega$  (brown-black-red-gold)..... **R1 – R5**
- Capacitors:**  
 [ ] (1) 33uF 50v Electrolytic Capacitor..... **C1**  
 [ ] (1) .1uF..... **C2**
- Semiconductors:**  
 [ ] (1) 1N4002 Diode..... **D1**  
 [ ] (1) Red LED (Shows Power Status)..... **D2**  
 [ ] (1) LM78L05 – 5 volt regulator TO-92 Case... **U1**  
 [ ] (1) LED Rainbow Processor..... **U2**  
 [ ] (3) STP36NF06 N-Channel MOSFET.... **Q1 – Q3**
- Sockets, Headers, Connectors and Switches:**  
 [ ] (1) 8-pin DIP Socket..... **U2**  
 [ ] (1) PCB mount pushbutton switch..... **S1**  
 [ ] (1) PCB mount pushbutton - Optional..... **S2**
- [ ] (1) Optional - DC Power Jack..... **P1**  
 [ ] (3) Rising Clamp Terminal Block..... **J1, J2**

### Power Supply Options

Power to the **LED Rainbow** is applied by one of two options. It is important that only one power connection is used leaving the secondary power option disconnected. With power applied, LED indicator at **D2** should light up.

A DC Power Jack can be installed at position **P1**. This layout allows for various styles of connectors to be used, the most common being a 2.1mm barrel-jack.

Connector **J1** accepts a two-position rising clamp terminal which simplifies applying power to the system.

Typical power ratings for this board need to match the voltage and current ratings of the LEDs you are driving. Normally a 12v-16v DC adapter providing current at a minimum of 200mA.

### Connections To The Board

Outputs on the **LED Rainbow** are located to the right of the board. A total of three outputs are available, labeled **R**, **G** and **B**. **R** represents Red, **G** for Green and **B** for Blue. Outputs can be soldered directly to the board, or you can install professional grade rising clamp terminals that make wiring and experimentation easy. The terminal blocks are included in the parts kits we supply.

The outputs utilize a common anode display technology. The anode (positive) of each output is common and only the cathode (negative) is switched or controlled via PWM.

Although the driver MOSFETs can control up to 30A, you are limited to the current being applied to the power input.

### Operation

When powered up the first time, it will begin running the first sequence. As **S1** is pressed, the next sequence will be selected with subsequent presses selecting the next available routine.

When cycling through the various sequences, approximately 10 seconds after you release **S1** on a sequence, the system will automatically remember the sequence you are on. When the **LED Rainbow** is next powered on later, it will remember your last saved sequence and immediately start displaying it.

The system also features a power saver mode. With the power on, press and hold **S1** for approximately 2 seconds, putting the system into sleep mode. While in sleep mode, press **S1** for about 2 seconds and release to wake the PIC from sleep. If **S1** isn't held for two seconds the PIC returns to sleep preventing the circuit from being accidentally turned on. When sleeping, the **LED Rainbow** draws only a few microamps.

The latest board design includes a mounting location for a secondary push-button at S2. This is for future expansion and is not currently used.

### Share Your Effects!

The versatility of the **LED Rainbow** is its open architecture. If you have a lighting sequence you have created that you would like to share with others, please contact us and we can include it as a download from our site. If you have an idea for a sequence but are not up to writing the code, contact us – we will see if we can write the routine for you.

