

LED Beam Mini LED Lite Bar

LED Beam – Mini 4-Inch LED Lite Bar

Light Emitting Diodes (LEDs) are an attractive, economical and convenient option for lighting applications. Available in a wide variety of colors and sizes, LEDs provide for low-voltage, low-cost, highly-reliable lighting solutions. Applications range from lighting in aquariums, recreational vehicles, marine & aircraft vehicles to computer case mods, under-vehicle lighting, emergency/security lighting and accent-lighting at home – the options are endless.

One challenge with LEDs is the mounting of the individual displays. We have produced the **LED Beam**, a versatile mounting system which holds a total of six equally-spaced LEDs on a compact 4" x 3/8" (9mm x 102mm) display board. Shown below is a slightly enlarged layout of the **LED Beam**, clearly showing the mounting of the six LEDs and two resistors.

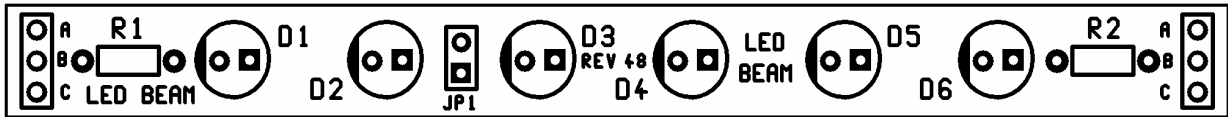

The **LED Beam** board design allows for the six LEDs to be controlled in sets of three. As power is applied to connection "A" and "B", LEDs at position D1, D3 and D5 will illuminate. Alternately, as power is applied to connection "A" and "C", LEDs at position D2, D4 and D6 will illuminate.

Common to each of the lighting options is connection "A", which is the common ground (negative or cathode); while connection "B" and "C" are where power (positive voltage or anode) is applied. The schematic outlines the connectivity available on the **LED Lite** display board.

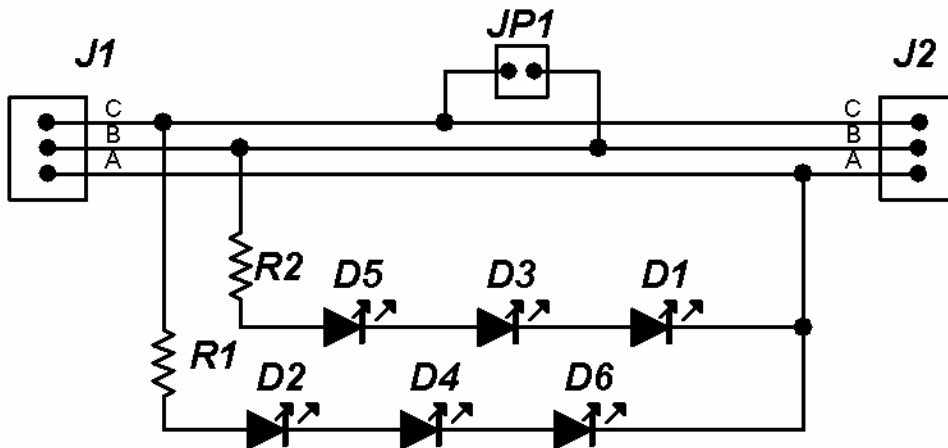

As an added convenience to the **LED Beam**, an option has been included to allow a single power supply to be utilized between connections "A" and "B" that will allow all six LEDs to illuminate. This is accomplished by soldering a jumper across JP1. Simply apply voltage to connections "A" and "B" and all six LEDs will illuminate. Resistors are still required at R1 and R2.

Another exclusive feature of the **LED Beam** board allows you to chain the output of one board to the input of another. Connect the "A", "B" and "C" outputs on one board to the corresponding inputs on the next board. The "A", "B" and "C" connections are connected straight through on the board so either end can be an input or output to connect to the next board. Care should be taken to only connect up to a maximum of four boards in the manner.

Using LEDs does require care to limit the maximum current through the circuit – this is known as Current Limiting. Current Limiting is the process of restricting or controlling the total current draw of a circuit with the use of resistors.

This is accomplished on the **LED Beam** with current limiting resistors located at positions *R1* and *R2*. *R1* limits the current for LEDs *D2*, *D4*, and *D6*, while *R2* limits the current through LEDs *D1*, *D3*, and *D5*.

The value of the current limiting resistor is determined by the supply voltage to the circuit, the voltage drop across each LED and the current desired through the circuit. As a rule, keep the current through each leg of the circuit to approximately 20mA to 25mA, which is normally the standard for LEDs. The chart below will assist you in determining the correct dropping resistor needed for your specific application.

For example, if you were going to run a set of Blue LEDs in an automobile, the normal battery voltage of a car is approximately 13.8v. Based on the chart, the supply voltage is between 13.5v and 14.0v and the Blue LED option shows you would require a 150 ohm dropping resistor.

If you purchased our full kit, you will find a 150-ohm resistor, which has a color code of brown-green-brown-gold. The color code was determined from the reference table below the Resistor Selection Chart. The full kit includes two resistors of each value listed for a total of 18 resistors.

Resistor Selection Chart			
LED Type/Color	Blue, UV & Green	White & Pink	Red & Yellow
LED Forward Voltage	Vf=3.5v	Vf=3.0v	Vf=2.0v
Supply Voltage	13.5v to 14.0v	150-ohm	220-ohm
	13.0v to 13.4v	120-ohm	200-ohm
	12.5v to 12.9v	100-ohm	150-ohm
	12.0v to 12.4v	68-ohm	150-ohm
	11.5v to 11.9v	47-ohm	120-ohm

Resistor Color Codes		
330-ohm (orange-orange-brown-gold)	270-ohm (red-violet-brown-gold)	220-ohm (red-red-brown-gold)
200-ohm (red-black-brown-gold)	150-ohm (brown-green-brown-gold)	120-ohm (brown-red-brown-gold)
100-ohm (brown-black-brown-gold)	68-ohm (blue-grey-black-gold)	47-ohm (yellow-violet-black-gold)

It is important that you use the correct current limiting resistor, as using a value too low can result in permanent damage to the LEDs in your circuit. If you use a value larger than is needed, the LEDs will not glow as brightly but no damage will occur.

As a final mounting option for your **LED Lite**, you can encase your board in a see-thru plastic or acrylic tube. This will protect the board from outside contaminants or inclement weather to prolong the usefulness of your LEDs and board. We also have available high-quality tubes complete with end caps to complete your project.

