



LED Lighting Effects Controller

The **LED fx** is an extremely simple and effective design - specifically engineered to control 16 individual output ports. Each port has an LED attached to it, allowing for attractive effects to be achieved by running customized code on the built-in PIC processor.

The unique design allows for the selection of various lights effects stored on the processor by selecting a routine from the onboard DIP switch. The processor will run the built-in routine selected and display the output on the LEDs.

The outputs are buffered through a ULN2803 8-bit TTL-Input NPN Darlington sink driver – which allows for the control of high-current devices from a single processor pin. Each Darlington can handle a maximum of 500mA of continuous current at a maximum of 50V – making the ULN2803 well suited to provide an interface between the low logic levels of the processor to higher current/voltage devices such as relays, solenoids, motors, lamps, LEDs and other devices.

The **LED fx** is a high quality, double-sided board, complete with solder masks on both sides, plated holes along with a high-contrast silk-screen labeling component positions. The board is a compact 3 15/16" x 3 15/16" (100mm x 100mm) ready to fit into standard size project cases.

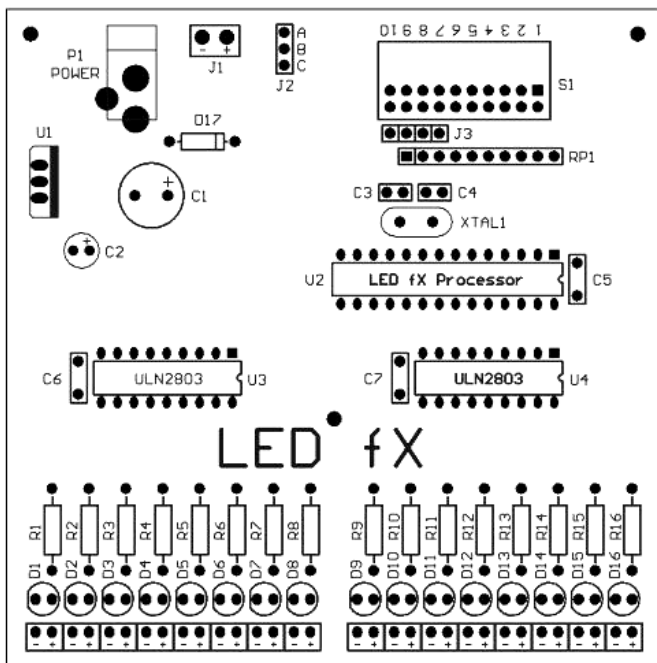

Along with sixteen LED displays, sixteen individual connections are provided just below each LED where you have the ability to connect custom accessories such as lamps, motors or solenoids. These will be toggled on and off at the same time as the LEDs are controlled.

Component List

Resistor 1/2 watt, 5% Carbon Film:

- [] (1) 510 Ω (green-brown-brown-gold) **R1 - R16**

Resistor Pack:

- [] (1) 10K Ω (10-Pin, 9 Resistors)..... **RP1**

Capacitors:

- [] (1) 100uF 35v Electrolytic Capacitor..... **C1**
- [] (1) 10uF 25v Electrolytic Capacitor..... **C2**
- [] (2) 15pF..... **C3, C4**
- [] (3) .1uF..... **C5, C6, C7**

Semiconductors:

- [] (1) Blue LEDs..... **D1 – D8**
- [] (1) White LEDs..... **D9 – D16**
- [] (1) 1N4002..... **D17**
- [] (1) LM7805 – 5 volt regulator TO-220 Case... **U1**
- [] (1) LED fx Processor..... **U2**
- [] (2) ULN2803A Octal Peripheral Driver..... **U3, U4**

Crystal:

- [] (1) 4Mhz Crystal HC49 Case **XTAL1**

Sockets, Headers, Connectors and Switches:

- [] (1) DIP Switch – 10 Positions..... **S1**
- [] (1) 28-pin DIP Socket **U2**
- [] (1) 18-pin DIP Socket **U3, U4**
- [] (1) 1x3-pin male header..... **J2**
- [] (2) 2-pin Jumper – Push On..... **J1**
- [] (1) DC Power Coaxial Jack PCB..... **P1**

Power Supply Options

Power is typically applied through the supplied DC adapter on the power supply connection at **P1**. The DC adapter provides approximately 16V DC at 400mA.

Power to LEDs and Outputs

Important: Connector **J2** normally has a shorting-block across pins **B-C**. Power from **P1** is applied to the outputs and LEDs. No jumper will prevent the drivers **U3/U4** to function and the LEDs will not light.

If desired, the jumper block at **J2** can be moved across terminals **A-B**. This will power the LEDs and outputs directly from the onboard 5V regulator. The LEDs will not glow as brightly, but will still give a stunning effect.

J1 – Alternate Power Input – Use With Caution!

J1 has been provided for advanced users – failure to understand its proper operation can destroy your board!

If alternate power (higher voltage or current) is required at outputs **U3/U4**, you can provide DC to **J1**. There must be **NO JUMPERS** across **J2** – there must be **NO** connection between **A-B** or **B-C**.

Technical Details

The **LED fX** is designed around the Microchip microcontroller. Outputs of *Port B* and *Port C* directly drive the ULN2803 Octal Drivers which provide high-current switching. The ULN2803 also drives the LEDs at **D1** to **D8** (*Port B*) and **D9** to **D16** (*Port C*).

Control of the lighting effects is done through the switch at **S1**, which is on *Port A* of the processor. Six inputs are available for a total of 64 different combinations.

Coding to control the **LED fX** is written in a development environment called *Proton Plus Compiler*. All source code for the effects code is available for free download from our web site at <http://www.pcboard.ca>, complete with compiled HEX files to allowing you to program your own processors if desired. Alternately, pre-programmed processors are available at directly from us.

Board Assembly

The **LED fX** is available as a fully assembled and tested product, as a kit of components you can build at home, or just the bare board which you can supply your own components for. Average assembly time of the kit can be accomplished by the novice builder in 60 to 90 minutes.

Effects Selection

Effects are individually selected by setting the programming DIP switch at **S1**. 64 selections are available from the DIP switches, although not every chip will have 64 different selections available for viewing. Various effects chips are available and will include details on the effects along with the code necessary to access that effect.

The selection is accomplished by entering the Binary value of the effect desired.

Value	DIP Switch (S1) Positions						
	1	2	3	4	5	6	7-10
0	Up	Up	Up	Up	Up	Up	n/a
1	Down	Up	Up	Up	Up	Up	n/a
2	Up	Down	Up	Up	Up	Up	n/a
3	Down	Down	Up	Up	Up	Up	n/a
4	Up	Up	Down	Up	Up	Up	n/a
5	Down	Up	Down	Up	Up	Up	n/a
6	Up	Down	Down	Up	Up	Up	n/a
7	Down	Down	Down	Up	Up	Up	n/a
8	Up	Up	Up	Down	Up	Up	n/a
9	Down	Up	Up	Down	Up	Up	n/a
10	Up	Down	Up	Down	Up	Up	n/a
11	Down	Down	Up	Down	Up	Up	n/a
12	Up	Up	Down	Down	Up	Up	n/a
13	Down	Up	Down	Down	Up	Up	n/a
14	Up	Down	Down	Down	Up	Up	n/a
15	Down	Down	Down	Down	Up	Up	n/a
16	Up	Up	Up	Up	Down	Up	n/a
17	Down	Up	Up	Up	Down	Up	n/a
18	Up	Down	Up	Up	Down	Up	n/a
19	Down	Down	Up	Up	Down	Up	n/a
20	Up	Up	Down	Up	Down	Up	n/a
21	Down	Up	Down	Up	Down	Up	n/a
22	Up	Down	Down	Up	Down	Up	n/a
23	Down	Down	Down	Up	Down	Up	n/a
24	Up	Up	Up	Down	Down	Up	n/a
25	Down	Up	Up	Down	Down	Up	n/a
26	Up	Down	Up	Down	Down	Up	n/a
27	Down	Down	Up	Down	Down	Up	n/a
28	Up	Up	Down	Down	Down	Up	n/a
29	Down	Up	Down	Down	Down	Up	n/a
30	Up	Down	Down	Down	Down	Up	n/a
31	Down	Down	Down	Down	Down	Up	n/a
32	Up	Up	Up	Up	Up	Down	n/a

Sharing Your Effects!

The versatility of the **LED fX** is its open architecture. If you have a lighting sequence you have created that you would like to share with others, please contact us and we can include it as a download from our site. If you have an idea for a sequence but are not up to writing the code, contact us – we will see if we can write the routine for you.