



## BasicX-24™ / BASIC Stamp® Prototype Board

The **Proto-24** is a general-purpose prototyping platform used with single chip embedded processors such as the NetMedia BasicX-24™ and the Parallax BASIC Stamp® 24-pin devices (BASIC Stamp 2, Stamp 2e Stamp 2sx and Stamp 2SX Plus). Included onboard is a regulated power supply, DB-9 connector for attaching to a host computer system, reset circuitry and over 800 plated-through holes on the prototype surface.

The **Proto-24** is a high quality prototype board, complete with solder masks on both sides of the board, plated holes along with a high-contrast silk-screen labeling component positions. Board size is a compact 3 5/8" x 5" (920mm x 1270mm) ready to fit into standard size project cases such as the Radio Shack ABS plastic project case (270-1806).

### Parts List

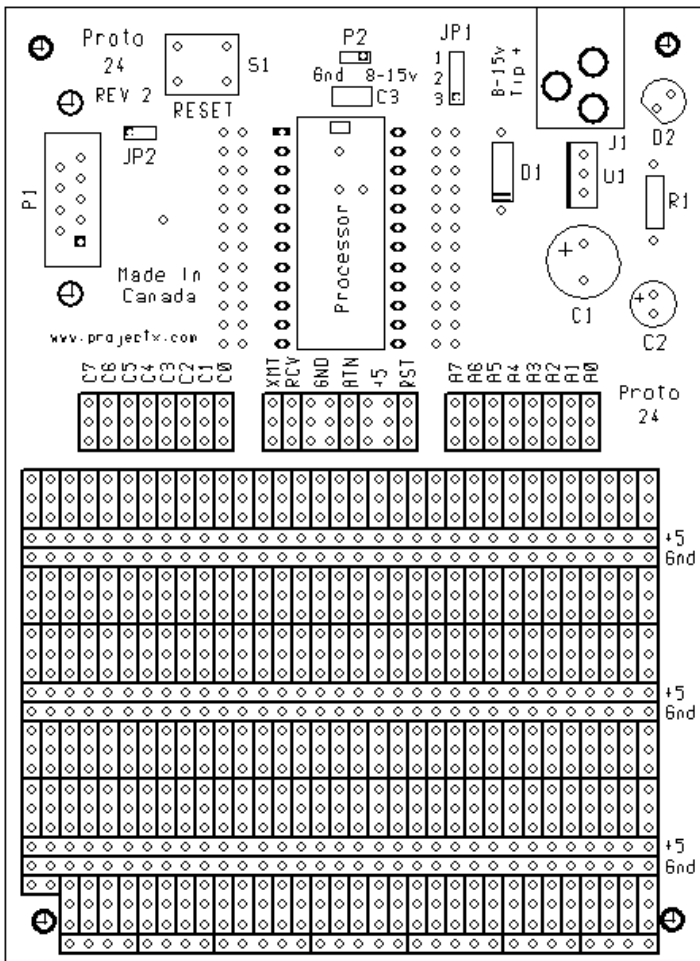

#### Resistor 1/4 watt, 5% Carbon Film:

- [ ] (1) 220 Ω (red-red-brown-gold) ..... **R1**

#### Capacitors:

- [ ] (1) 100uF 35v..... **C1**
- [ ] (1) 10uF 25v ..... **C2**
- [ ] (1) .1uF ..... **C3**

#### Semiconductors:

- [ ] (1) LM7805 – 5 volt regulator TO-220 Case... **U1**
- [ ] (1) 1N4002..... **D1**
- [ ] (1) Red LED Power Indicator ..... **D2**
- [ ] (1) BasicX-24™ or BASIC Stamp®... **Processor**

#### Sockets, Headers, Connectors and Switches:

- [ ] (1) 24-pin DIP Socket..... **Processor**
- [ ] (1) 1x3-pin male header ..... **JP1**
- [ ] (1) 1x2-pin male header ..... **JP2**
- [ ] (2) 2-pin Jumper – Push On..... **JP1, JP2**
- [ ] (1) DB9 Female PCB Right Angle Connector .**P1**
- [ ] (1) 2.1mm Coaxial Jack PCB..... **J1**
- [ ] (1) PCB mount pushbutton switch..... **S1**

#### Initial Setup Notes:

- 1) Jumper **JP1** must be installed in position **2-3** when applying power (**8-15v DC**) on DC power jack **J1**. This requires the power supply section (**C1, C2, C3, U1, D1**) of the **Proto-24** to be populated with components.
- 2) Programming enable jumper (**JP2**) must be installed. *Failure to install the jumper will write-protect the processor and not allow programming of the processor.*

### On-board Power Supply Options

There are several options available on the **Proto-24** to supply power to the processor.

**Option 1 (Preferred):** This option allows for **8-15v DC** to be applied to DC power jack **J1**. The center pin of **J1** is positive. Jumper block at position **JP1** should have a shorting-block placed across terminals **2-3**. When installed, unregulated power on **J1** is filtered and regulated through the onboard regulator circuitry and finally power applied to **pin 21** of the processor. The parts necessary to be installed for the regulated power section include: **J1, JP1, D1, U1 C1, C2** and **C3**. When power is applied to the circuit through this option, the processor is protected against reverse currents by diode **D1**, offering extra protection to the circuit.

**Option 2:** Allows for **8-15v DC** to be applied to power jack **J1**, again the center pin of **J1** must be positive. The jumper block at position **JP1** should have a shorting-block placed across terminals **1-2**. While in this mode of operation, the unregulated current is provided directly to **Pin 24** of the Processor to the voltage regulator built on the chip. It is suggested that **C3** be installed while **LED D2** and resistor **R1** not be installed. This will reduce the overall current load placed on the on-chip regulator. *This option should only be used when current driving limitations of the on-chip regulator built onto the processor are fully understood.*

**Option 3:** When you desire not to use **J1** to provide unregulated voltage to the system, **8-15v DC** can be applied at position **J2** on the **Proto-24**. The jumper block at position **JP1** should have a shorting-block placed across terminals **2-3**. The components needed to regulate the voltage are the same as in *Option 1*.

### On-board Power Indicator

An LED option has been included on the **Proto-24** at position **D2** along with a current limiting resistor at **R1**. Although a handy option to show when the **Proto-24** is powered on, the LED arrangement draws approximately 20mA of current.

### Programming Protection Jumper

A special jumper block has been included on the board. When **JP2** has its shorting-block **removed**, this will prevent any software trying to reprogram or erase the processor from the DB-9 serial port. *It is very important to remember to install a shorting-block across JP2 in order to program your processor.*

### System Reset

Included on the board at position **S1** is an optional reset switch. When depressed, the processor will restart.

### Prototype Area

The prototype area of the **Proto-24** has been optimized to provide maxim overall space and power options. Over 800 holes have been provided with three sets **+5v** and **GND** power tracks. In addition each of the specific processor pins has been extended out to three separate pins for each signal to allow for easy access during interfacing.

### Board Mounting

During the design phase of the **Proto-24**, much consideration was given to mounting the PCB in a case. The board has been designed to fit securely in the Radio Shack ABS plastic project case (270-1806).