

Proto-28

Rev II

Proto-28 – PICmicro Prototype Board

The **Proto-28** is a general-purpose prototyping platform to evaluate Microchip PIC based microcontroller products. Supported devices include most of the Microchip 28-pin devices including the PIC 16F72, 16F76, 16F870, 16F871, 16F872, 16F873, 16F876, 18F242, 18F252, 18F442, 18F452 and others. Included onboard is a full peripheral set including a header for in-circuit programming of flash devices, true RS-232C serial input/output with mounting for an onboard DB-09 connector, regulated power supply circuitry, reset circuitry and over 740 plated-through holes on the prototype surface.

The **Proto-28** is a high quality prototype board, complete with solder masks on both sides of the board, plated holes along with a high-contrast silk-screen labeling component positions. Board size is a compact 3 5/8" x 5" (9.2cm x 12.7cm) ready to fit into standard size project cases such as the Radio Shack ABS plastic project case (270-1806 or 270-1807).

Parts List

Resistors 1/4 watt, 5% Carbon Film:

- [] (3) 10K Ω (brown-black-orange-gold) **R1, R4, R5**
- [] (1) 100 Ω (brown-black-brown-gold)..... **R2**
- [] (1) 330 Ω (orange-orange-brown-gold)..... **R3**

Capacitor:

- [] (1) 100uF 35v..... **C1**
- [] (1) 10uF 25v **C2**
- [] (1) .1uF..... **C3**
- [] (4) 1uF 35v **C4, C5, C6, C7**
- [] (2) 15pF..... **C8, C9**

Semiconductors:

- [] (1) 1N4002 **D1**
- [] (1) Red LED Power Indicator **D2**
- [] (1) 1N914 or 1N4148 **D3**
- [] (1) LM7805 – 5 volt regulator TO-220 Case..... **U1**
- [] (1) MAX232CPE..... **U2**
- [] (1) 28-Pin PIC Processor Location..... **U3**

Crystal:

- [] (1) 4Mhz-20Mhz Crystal HC49 Case **XTL1**
optional
- [] (1) 4Mhz-20Mhz Ceramic Resonator **XTL1**

Sockets, Headers, Connectors and Switches:

- [] (1) 16-pin DIP Socket..... **Position U2**
- [] (1) 28-pin DIP Socket..... **Position U3**
- [] (1) 2.1mm or 2.5mm Coaxial Jack PCB **J1**
- [] (1) 5-pin ICP Programming Header..... **J2**
- [] (1) 1x2-pin male header **J3**
- [] (1) DB9 Female PCB right angle connector **J8**
- [] (4) 1x3-pin male header **P1, P2, P3, P4**
- [] (1) PCB mount pushbutton switch..... **RESET / S1**
- [] (4) 2-pin push-on jumper **P1, P2, P3, P4**

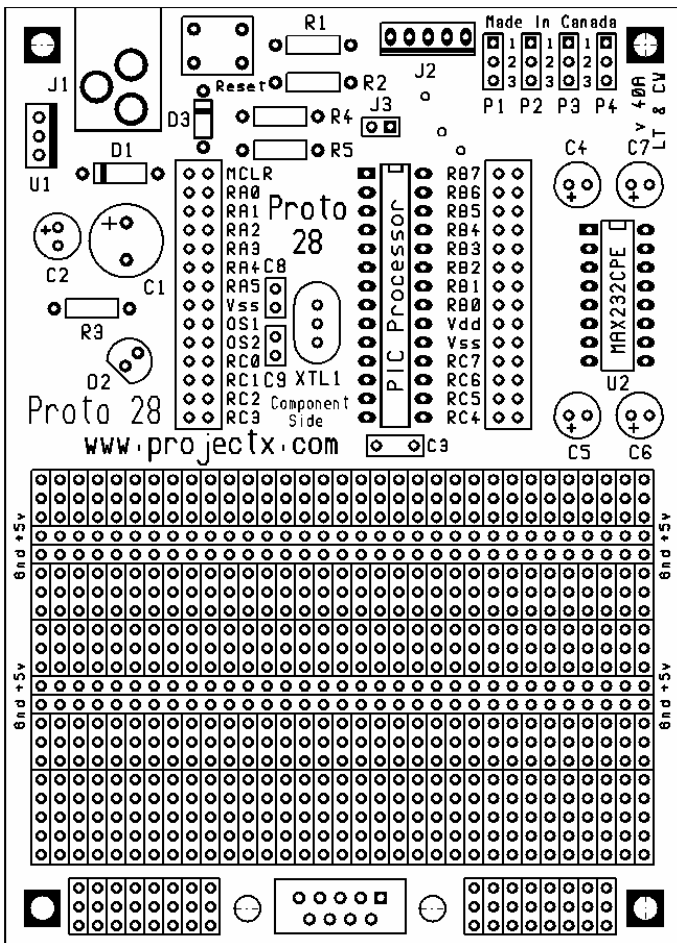

On-board Power Supply

The power supply circuit on the **Proto-28** board is designed to accept an 8-15v DC power source. Power should be applied to the connector at *J1*, with the centre pin of the power jack being positive (+). Total current available from the regulator will be about 1/2 amp, but can be driven to approximately 1 amp with the addition of a heat sink on the LM7805 regulator.

LED Power Indicator

An LED option has been included on the **Proto-28** at position *D2* along with a current limiting resistor at *R3*. Although a handy option to show when the **Proto-28** is powered on, the LED arrangement draws approximately 20mA of current. In applications where lower power consumption is desired, the LED (*D2*) or current limiting resistor (*R3*) can be removed without affecting the operation of the rest of the board.

System Reset

Included on the board at position *RESET* is an optional reset switch. When depressed, the processor will restart.

ISP (In-Circuit Programming Port)

A special port is included on the **Proto-28** board at *J2*. This port allows for the programming of the processor while it remains on the prototype board.

Programming port *J2* has been designed to plug directly into the WARP-13a ISP port. The pin connections are a one-for-one match, meaning pin-1 of the **Proto-28** connects directly to pin-1 of the WARP-13a ISP port.

During the in-circuit programming process, certain pins of the processor are toggled by the programmer. Pins 27 (*RB6*), 28 (*RB7*) and 1 (*MCLR*) are all connected to the programmer. If your custom circuit constructed on the **Proto-28** board uses any of these pins, they may interfere with the programming process. For this reason, three-position jumper blocks have been included at *P2* for *RB6* and *P1* for *RB7*. When programming the processor, a jumper needs to be at positions 2-3 on both *P1* and *P2*.

As an added step during programming, the "Low-Voltage ICSP Programming Enable" needs to be at specific logic levels. Processor pin 26/*RB5* or pin 24/*RB3* must be pulled low during programming. The model of processor installed will determine whether *RB5* or *RB3* port needs to be driven low. Consult the "In-Circuit Programming Jumper Chart" to determine the correct jumper settings for the various processor options.

Jumper *J3* allows for VDD (+5v) from the ICP port to be connected to the **Proto-28** board. Normal configuration is to leave the jumper removed from *J3*.

In-Circuit Programming Jumper Options

Jumper Option	Normal Operation	Programming Mode			
		16F72 16F76	16F870 16F871 16F872 16F873 16F876	18F242 18F252 18F442 18F452	
RB7 P1	1-2	2-3	2-3	2-3	
RB6 P2	1-2	2-3	2-3	2-3	
RB5 P3	1-2	1-2	1-2	2-3	
RB3 P4	1-2	2-3	2-3	1-2	

Clock Source

The **Proto-28** has the ability to support various clock options. The system has been tested with crystals ranging from 4 MHz to 20 MHz at position *XTL1*. *XLT1* can be substituted with a ceramic resonator. If using a ceramic resonator, remove capacitors *C8* and *C9*.

RS-232C Serial Interface

A full RS-232C serial interface is built on to the **Proto-28** board with a MAX232CPE at *U2*. To isolate *RX* (*Serial In*) and *TX* (*Serial Out*) processor pins (*RB1* and *RB2*) from the MAX232CPE, simply remove the MAX232CPE from its socket.

Prototype Area

The prototype area of the **Proto-28** has been optimized to provide maximum overall space and power options. Over 740 holes have been provided with two sets of **+5v** and **GND** power tracks. In addition, each processor pin has been extended out to two separate pins for each signal to allow for easy access during interfacing.

Board Mounting

During the design phase of the **Proto-28**, much consideration was given to mounting the PCB in a case. The board has been designed to fit securely in the Radio Shack ABS plastic project case (270-1806 or 270-1807).

Quick Start – Configuring Your Proto-18

Once you have completed construction of your **Proto-28**, you will be anxious to put it into operation. For regular use, ports *P1*, *P2*, *P3* and *P4* should each have a shorting-jumper block placed across the 1-2 terminals.